



# SOLO 1-Tank Monitoring / Display & External Sensor Installation Manual Version 2.3

## INTRODUCTION

The sensor is designed for use with plastic or fiberglass-walled aqueous fluid tanks (not fuel) up to 3/4-inch in thickness. Fiberglass tanks cored with plywood, foam, or metal may give inaccurate readings. Metal tanks require the SCAD internal level sensor. The monitor is compatible with SCSD non-contact level sensors, non-contact sensors manufactured by some other companies, and standard 240-33 Ohm float level sensors.

## REQUIRED TOOLS AND MATERIALS

Tape measure • pencil • permanent marker • isopropyl alcohol • screw driver • keyhole or jig-saw • 7 butt-splice terminations and wire termination tools • drill and drill bits • 18 AWG stranded wire in 3 colors: (preferably red, blue, and black) • Two, 2" strips of double-sided tape to attach the monitoring panel or four #6 stainless steel sheet metal or wood screws between 3/8" and 1/2" long • If your tank has a waxy surface, over-spray the edges of the aluminum sensor foil with 3M® Hi-Strength Spray Adhesive 90® or 3M® Spray Adhesive Super 77® (available at most hardware stores).

## INSTALLATION

### Step 1: Panel Installation

Locate the panel away from weather or spilled fluids. The panel must have 1 inch of clearance for the depth of the display panel electronic circuit board and sensor wiring. Cut a rectangular hole in which to install the monitoring panel and its related wiring.

- 1) Mark the perimeter of the opening. This hole should be 1 1/2 inches high by 2 3/8 inches wide. Take care to mark the opening so that it is square with the floor and walls of your boat.
- 2) Saw the opening.
- 3) Hold the panel in place in the opening and mark the location on the wall of the panel's four-corner mounting holes if you are using screws for attachment.
- 4) Remove the panel and drill four pilot holes for the screws that will be used to secure the panel. Do not mount the panel yet.

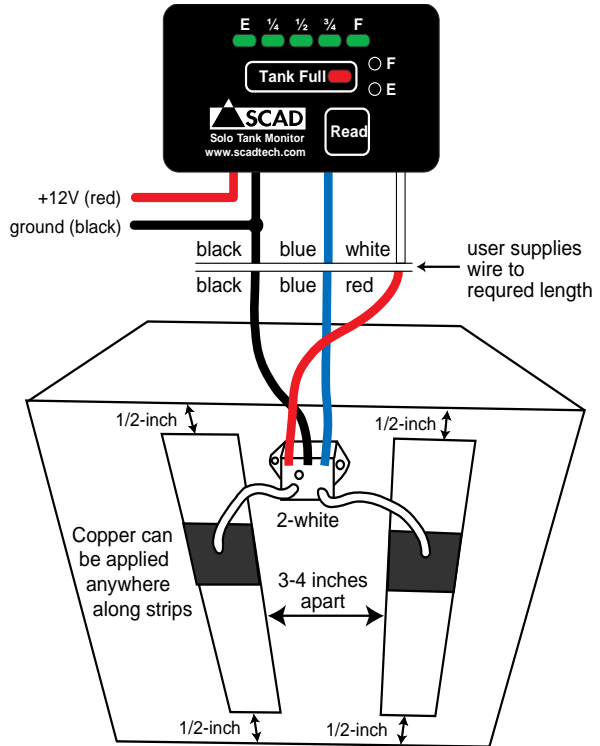

Figure 1

## Step 2: Sensor Foil Application

The non-contact sensor includes a pair of 2" wide aluminum tape strips (supplied) applied to the outside of the tank. Choose an area to apply these strips that has easy access and allows the strips to span the full height of the tank. Avoid areas near conductive objects such as metal objects, water supply lines or drains, and wiring harnesses. Due to variances in tank shape and the possibility of restricted access to suitable tank walls, you may not be able to follow these instructions exactly. In this case, try to get your installation as close as possible to these recommendations. The monitoring panel software can compensate for most minor sensor installation variances.

- 1) The kit provides 60" of foil for up to two 30" sensor strips. Measure the height of the tank and cut 2 sensor foil strips that are 1" shorter than the height measurement (i.e. if the tank is 18" high, you should cut the sensor strips 17" long). Flatten the cut strips.
- 2) Lightly scrub the tank area with a 3M® Scotchbrite® pad or equivalent and then clean the area with isopropyl alcohol. Allow cleaned area to dry completely before applying the Aluminum tape strips.
- 3) The sensor strips should be positioned 3" to 4" apart on the tank wall; they should also be positioned 1/2" from the top and bottom of the tank. Use tape measure and permanent marker to mark the positions on the tank wall.
- 4) Remove the paper backing. Some plastic tanks exude a waxy substance, which could cause the aluminum tape to shed off of the tank wall over time. In this case, you can over-spray the edges of the aluminum sensor foil with 3M Hi-Strength Spray Adhesive 90 or 3M Spray Adhesive Super 77 (locally available at most hardware stores). Using your marks as a guide, apply the foils as flatly as possible to the tank wall to ensure good adhesion. Do not worry if the strips are not perfectly flat, as it won't affect sensor output. The strips should be parallel and mounted at the same height. Rub the tape against the tank to remove bubbles.
- 5) Remove the paper backer from the back of the sensor module itself and apply it in between both of the tape strips.
- 6) Clean the surface of the Aluminum tape where the Copper patches will be applied, with alcohol. The copper patches can be mounted anywhere along the length of the Aluminum sensing strips. Remove the paper backing from each of the copper patches and apply them over the top of each of the cleaned aluminum tape strips.
- 7) We recommend you leave all the sensors exposed until you are finished testing your system.

## STEP 3: System Wiring

Route the wiring from the sensor to the panel as illustrated in Figure 1. Wire between the sensor to the panel is not included. Use at least 18 AWG stranded wire for all wiring, preferably in three colors: red, blue, and black. While it's possible to connect the black wire from the sensor to a low impedance ground to avoid running a third wire, we highly recommend running the black wire from the sensor to the panel to insure a good ground for proper operation. Route all wires so they are well away from potential heat sources (like the oven or exhaust pipes), and away from any moving parts. We recommend using nylon ties to secure the wires. Avoid using staples or nails to secure wiring.

Pull the wires from the sensor location all the way through the hole you created for the panel leaving enough slack on each wire so that it is easy to strip and splice to the back of the panel.

Strip about 5/16 inch from all wire and crimp-connect the sensor to the wires, and wires to the monitoring panel. Secure the panel into the hole you made in the wall. If using screws to secure the monitoring panel, do not over tighten these screws as you may damage the plastic face graphic.

## **STEP 4: Software Setup**

Set the Sensor Type: The SOLO is factory programmed for external sensor. If you're using an external sensor, you can skip this setup.

- 1) Press and hold the "Read" button. You should see a light turn on. Release the button and the light will go out. Within 5 seconds after the lights go out, press the "E" button to set the sensor type as follows.
- 2) Each time you press the "E" button, lights turn on consecutively from left to right. It is recommended that you circle through the selections once. Select the light that corresponds to the following sensor types:
  1. The Empty light indicates an external foil sensor
  2. The  $\frac{1}{4}$  light indicates a solid-state rod-style sensor
  3. The  $\frac{1}{2}$  light indicates a 0-5V linear output sensor
  4. The  $\frac{3}{4}$  light indicates a 33-240 Ohm float sensor
- 3) Release the button. The light(s) will go out after 5 seconds indicating that the sensor type has been set.

Set the Tank Shape: The SOLO is factory programmed for a square tank. If you're measuring a square tank, you can skip this setup.

- 1) Press and hold down the "Read" button, you should see a light turn on. Release the button and the light will go out. Within 5 seconds after the lights go out, press the "F" button to set the tank shape as follows.
- 2) Each time you press the "F" button, lights turn on consecutively from left to right. It is recommended that you circle through the selections once. Select the light that corresponds to the following tank shapes:
  1. The Empty light indicates a square tank
  2. The  $\frac{1}{4}$  light indicates a tank with a tapered cross-section
  3. The  $\frac{1}{2}$  light indicates a tank with a more exaggerated tapered cross section
  4. The  $\frac{3}{4}$  light indicates a tank with a circular cross section.
- 3) Release the button. The light(s) will go out after 5 seconds indicating that the tank type has been set.

## **STEP 5: Calibration**

Calibrated with the boat while it is in level and calm conditions.

Empty Calibration - Calibrate the empty point to the "pumped out empty" level. This is the level at which the tank has been pumped out and any remaining fluid in the plumbing has drained back into the tank. Calibrate the empty point by pressing and holding both the "Read" and "E" buttons simultaneously for at least 4 seconds

Full Calibration - Calibrate a waste holding tank just before it should be pumped out, and a potable water tank is just after filling. Calibrate the full point by pressing and holding both the "Read" button and "F" buttons simultaneously for at least 4 seconds. If possible, avoid calibrating holding tanks with fresh water since wastewater is not sensed exactly like fresh water.

**Error Checking** - The calibration software has error checking capabilities. If after you set a calibration point you see the 1/2 light blinking, it means that a full point is being set which is equal to or less than the empty point, or an empty point which is equal to or greater than the full point. When this error occurs, the calibration routine sets default empty and full values. This return to default values clears possible bad calibration data, which might make the sensor channel difficult to properly calibrate (i.e. an empty calibration value erroneously set with a full tank would otherwise prevent the setting of a proper full value until the empty point is set back to an appropriate empty value). If you continue to see this error after re-attempting calibration and re-checking the tank level, you may actually be experiencing a problem with the wiring between the sensor and panel (i.e. a disconnected power, sensor return, or ground wire to the sensor) or a bad sensor. If you suspect this may be the case, check the troubleshooting section in this manual.

## Troubleshooting

Problem	Possible Causes	Test / Remedy
Panel lights do not come on when pressing "Read" button.	Blown fuse or disconnected power or ground wires.	Check/replace fuse on power wire as needed. Check/repair poorly attached power and ground wires.
A tank channel always reads full, empty or never changes regardless of fluid level.	<ol style="list-style-type: none"> <li>1) Improperly calibrated tank.</li> <li>2) Damaged wiring between the display and sensor module.</li> <li>3) Damaged or improperly installed sensor foil.</li> <li>4) Damaged sensor module.</li> </ol>	<ol style="list-style-type: none"> <li>1) Recalibrate tank for empty and full and recheck.</li> <li>2) Check the wire connecting the sensor module to the display panel. Check/repair that all wires are attached securely and that there is no damage along the wire run (staples through wires are a common problem to look for). Recalibrate, and recheck.</li> <li>3) Check that the sensor foil is installed according to the instructions. Check that there is nothing "shorting out" the sensor foils (i.e.: metal object touching both foils), or that a large metal object is too close to the foils.</li> <li>4) Check that the white wires attached to the sensor modules have not disconnected from the copper patches or that the copper patches have not come loose from the aluminum sensor foil.</li> </ol>

**WARRANTY:** SCAD Technologies LLC (SCAD) warrants to the original purchaser that this product is free of defects in materials or workmanship for a period of one year from the product's date of purchase. [www.scadtech.com](http://www.scadtech.com)